

Field-oriented Control of Induction Motor Drives with Direct Rotor Current Estimation for Applications in Electric and Hybrid Vehicles

Chris Mi

Department of Electrical and Computer Engineering, University of Michigan-Dearborn, chrismi@umich.edu

Abstract

This paper demonstrates the implementation of field-oriented control and rotor current estimation of an induction machine. A mathematical model was developed in Matlab/Simulink. A control system was implemented on a three-phase wound field induction motor to confirm the proposed method and estimated rotor currents. A dSPACE embedded real time controller is used to implement the control and experimental results have been obtained to confirm the proposed method.

Keywords

induction machines, induction motors, field oriented control, rotor currents estimation, vector control, regenerative, brake, variable speed drives

1. INTRODUCTION

Induction motors have many advantages compared to DC machines and synchronous machines in many aspects, such as size, efficiency, cost, life span and maintainability. Low cost and ease of manufacturing have made induction machines a good choice for electric and hybrid vehicles [Chan, 2002]. However, one must be able to achieve energy regenerative braking and be able to control the torque and speed of an induction machine at low speeds in order to use an induction machine in traction drives such as hybrid electric vehicles. With field-oriented control, an induction machine can perform somewhat like a DC machine.

Squirrel-cage induction motors are of major interests because of their simplicity and low cost. The rotor currents of squirrel cage induction machines are not accessible. In order to control the speed and torque of an induction machine, one must establish a flux observer to estimate the magnetizing currents - a fictitious current [Mi, et al., 2002; Krause, 1987; Park, 1932; Belmans et al., 1993; Rahman and Zhong, 1995; Casadei et al., 1995; Jezernik, 1998; Pagano et al., 1999]. This paper demonstrates the theory and implementation of the field-oriented control of an induction machine with direct estimation of rotor currents.

2. VOLTAGE AND FLUX TORQUE EQUATIONS

When expressed as phasors in a general frame B , the voltage equation for a three-phase induction machine with three symmetrical stator windings is given as [Mi, et al., 2002]:

$$V_S^{(B)} = R_S i_S^{(B)} + p \lambda_S^{(B)} + j \cdot \lambda_S^{(B)} p \delta \quad (1)$$

$$V_R^{(B)} = R_R i_R^{(B)} + p \lambda_R^{(B)} + j \cdot \lambda_R^{(B)} p(\delta - \theta) \quad (2)$$

where p is the differential operand d/dt , V , I , and λ are phasors of voltage, current and flux linkage respectively, δ is the angle between B frame and stator, θ is the angle between the stator and the rotor flux, $(\delta - \theta)$ is the angle between the B frame and the rotor. Subscript S refers to the stator quantities and R refers to the rotor quantities respectively.

When expressed as phasors, the flux linkage can be expressed as:

$$\lambda_S = (L_m + L_{1\sigma}) \cdot i_S + L_m \cdot i_R \quad (3)$$

$$\lambda_R = L_m \cdot i_S + (L_m + L_{2\sigma}) \cdot i_R \quad (4)$$

where L_m is the mutual inductance and $L_{1\sigma}$ and $L_{2\sigma}$ are the stator and rotor leakage inductance respectively.

With the above equations, the mathematic model for an induction motor can be developed in Matlab/Simulink.

3. ROTOR CURRENT ESTIMATION

3.1 Rotor current observer

For squirrel cage induction machines, the rotor current i_R is not accessible. Therefore, a fictitious rotor magnetizing current i_{mr} is defined such that the rotor flux can be expressed in terms of this fictitious rotor magnetizing current and inductance:

$$\lambda_R = i_{mr} \cdot L_m \quad (5)$$

The rotor current can then be expressed as a function of magnetizing current and stator current from (4):

$$i_R = \frac{i_{mr} - i_S}{1 + \sigma} \quad (6)$$

where

$$\sigma = L_{2\sigma} / L_m \quad (7)$$

Substituting (5) and (6) to (2) and considering that V_R is normally set to 0 for squirrel-cage induction motors, the rotor equation can be re-written as:

$$0 = i_{mr} - i_s + T_r \cdot p i_{mr} + j \cdot T_r i_{mr} \cdot p(\delta - \theta) \quad (8)$$

where T_r is the rotor time constant which can be expressed as follows:

$$T_r = L_m(1 + \sigma) / R_R \quad (9)$$

If the rotor equation is written in the stator frame then $\delta=0$, $p\theta$ is equal to the rotor speed in electric degrees. Equation (8) has the following format:

$$0 = i_{mr} - i_s + T_r \cdot p i_{mr} - j \cdot T_r i_{mr} \cdot \omega \cdot (p/2) \quad (10)$$

Since the above equation is written on stator frame, we can write the α and β components of phasors i_s and i_{mr} :

$$\begin{aligned} i_s &= i_{s\alpha} + j i_{s\beta} \\ i_{mr} &= i_{mr\alpha} + j i_{mr\beta} \end{aligned} \quad (11)$$

Therefore (10) can be decomposed to its real and imaginary components, e.g.,

$$\begin{aligned} \frac{di_{mr\alpha}}{dt} &= \frac{1}{T_r} (i_{s\alpha} - i_{mr\alpha}) - i_{mr\beta} \cdot \omega \cdot (p/2) \\ \frac{di_{mr\beta}}{dt} &= \frac{1}{T_r} (i_{s\beta} - i_{mr\beta}) + i_{mr\alpha} \cdot \omega \cdot (p/2) \end{aligned} \quad (12)$$

Stator current can be easily transferred from abc system to ab system:

$$\begin{aligned} i_{s\alpha} &= i_{sa} \\ i_{s\beta} &= (i_{a\alpha} + 2i_{sb}) / \sqrt{3} \end{aligned} \quad (13)$$

Equation (12) can be implemented in Matlab/Simulink to observe $i_{mr\alpha}$ and $i_{mr\beta}$. Once this has been done, i_{mr} and δ_r can finally be calculated:

$$\begin{aligned} i_{mr} &= \sqrt{i_{mr\alpha}^2 + i_{mr\beta}^2} \\ \tan(\delta_r) &= i_{mr\beta} / i_{mr\alpha} \end{aligned} \quad (14)$$

where δ_r is the angle between i_{mr} and $i_{s\alpha}$.

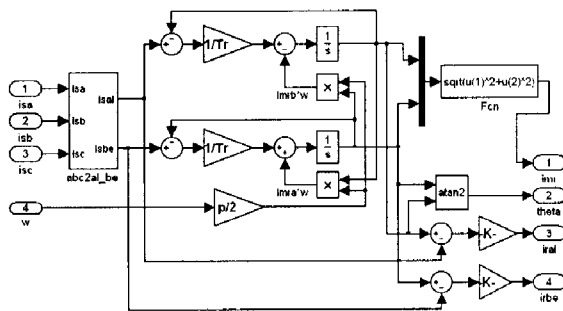

Fig. 1 Rotor current and magnetizing current observer

Rotor current are the differences between magnetizing current and stator current by using (6):

$$\begin{aligned} i_{r\alpha} &= (i_{mr\alpha} - i_{s\alpha}) / (1 + \sigma) \\ i_{r\beta} &= (i_{mr\beta} - i_{s\beta}) / (1 + \sigma) \end{aligned} \quad (15)$$

The mathematical model is implemented in Matlab/Simulink. Figure 1 shows the magnetizing current and the rotor current observer. In the model, the stator currents are transferred from abc coordinate to α - β coordinate using (13). The magnetizing currents are observed using (14). Angle between magnetizing current i_{mr} and stator current $i_{s\alpha}$ is calculated using (14). These rotor currents can be found using (15). The observed rotor currents are in the stator frame. Both stator and rotor current can now be transferred to d - q frame.

$$\begin{aligned} i_{sd} &= i_{s\alpha} \cos \delta_r + i_{s\beta} \sin \delta_r \\ i_{sq} &= -i_{s\alpha} \sin \delta_r + i_{s\beta} \cos \delta_r \end{aligned} \quad (16)$$

$$\begin{aligned} i_{rd} &= i_{r\alpha} \cos \delta_r + i_{r\beta} \sin \delta_r \\ i_{rq} &= -i_{r\alpha} \sin \delta_r + i_{r\beta} \cos \delta_r \end{aligned} \quad (17)$$

Figure 2 shows where the flux observer is used to observe the rotor current when the induction machine is open loop. The observed rotor current is first converted from abc frame to d - q frame and then converted to rotor

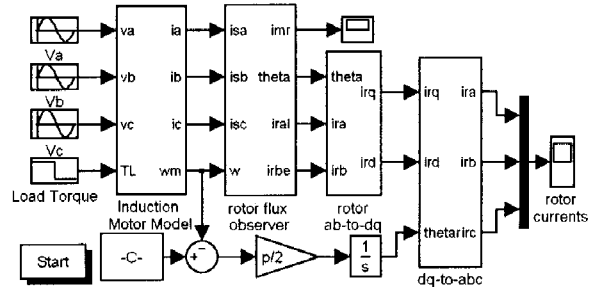

Fig. 2 Rotor current observation for open loop control of induction motor

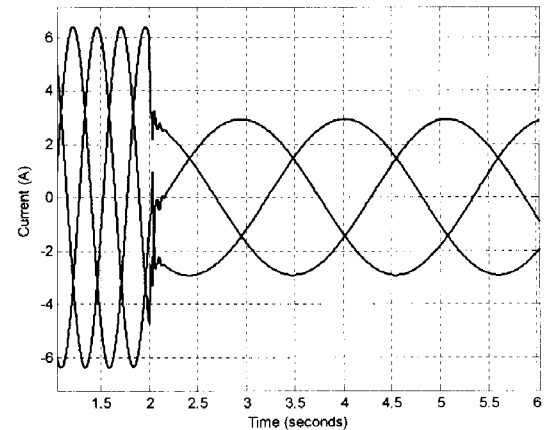

Fig. 3 Observed rotor current when load torque suddenly changed at t=2 seconds

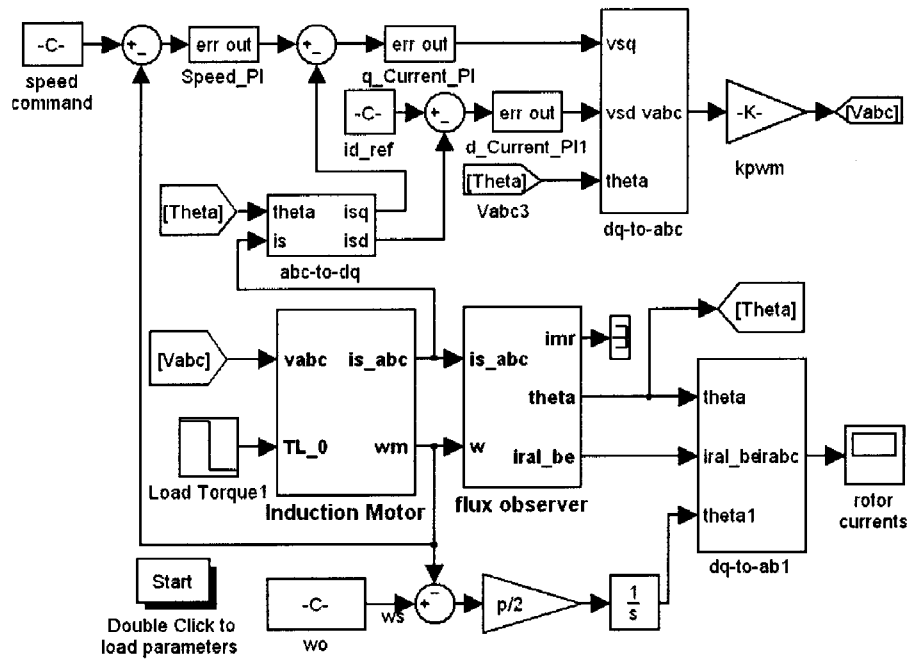

Fig. 4 Closed loop control of induction motor, model in Matlab/Simulink based on the rotor current observer

frame.

Figure 3 shows the observed rotor current for the open loop induction motor when load torque suddenly changes at t=2 seconds to half of its rated load.

4. CLOSED-LOOP CONTROL OF INDUCTION MOTOR

The purpose of field-oriented control is to control an induction machine in such a way that it behaves in a similar way that a dc motor does. An incremental encoder is used to measure the speed of the motor.

A Matlab/Simulink Model is then implemented for the closed loop control of induction motor as shown in Figure 4, based on the rotor current observer. The model is simulated and the observed rotor currents are shown in Figure 5, for a sudden load torque change at t = 4 seconds. Figure 6 shows that the speed is kept constant.

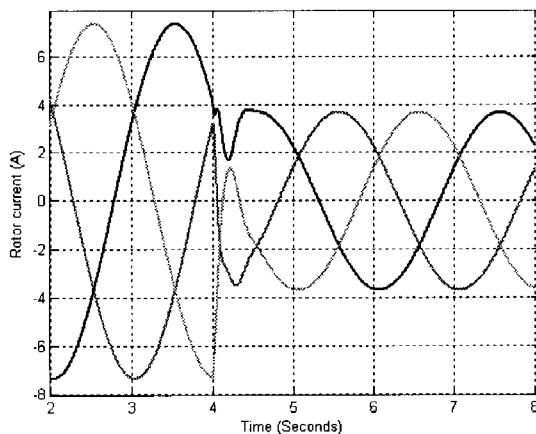

Fig. 5 Observed rotor current in Matlab/Simulink for closed loop control of induction machine

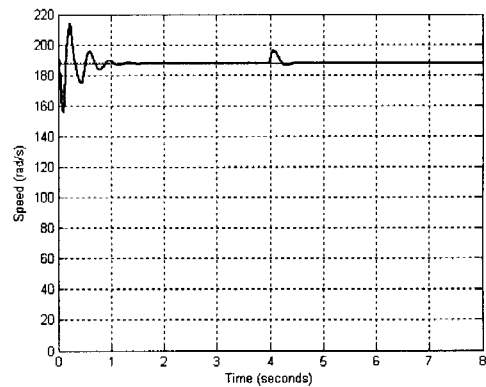

Fig. 6 Simulated motor speed in Matlab/Simulink for closed loop control of induction machine when load torque is suddenly changed at t = 4 seconds

5. EXPERIMENT WITH THE HELP OF DSPACE EMBEDDED REAL TIME CONTROLLER

A three-phase 3hp, 208V, 10.8A, 1800rpm wound rotor induction machine was tested to confirm the proposed method. The control system was implemented using dSPACE DS1104 embedded real time controller as shown in Figure 6. In the implementation, the induction motor model is replaced by the real motor. The PWM wave is generated and fed into a Powerex inverter. Both stator and rotor current are taken from the motor and fed to dSPACE analog-to-digital converter (ADC). Motor speed is measured using an incremental encoder. Figure 7 shows the implementation using dSPACE. Figure 8 shows measured rotor current compared with the estimated rotor current.

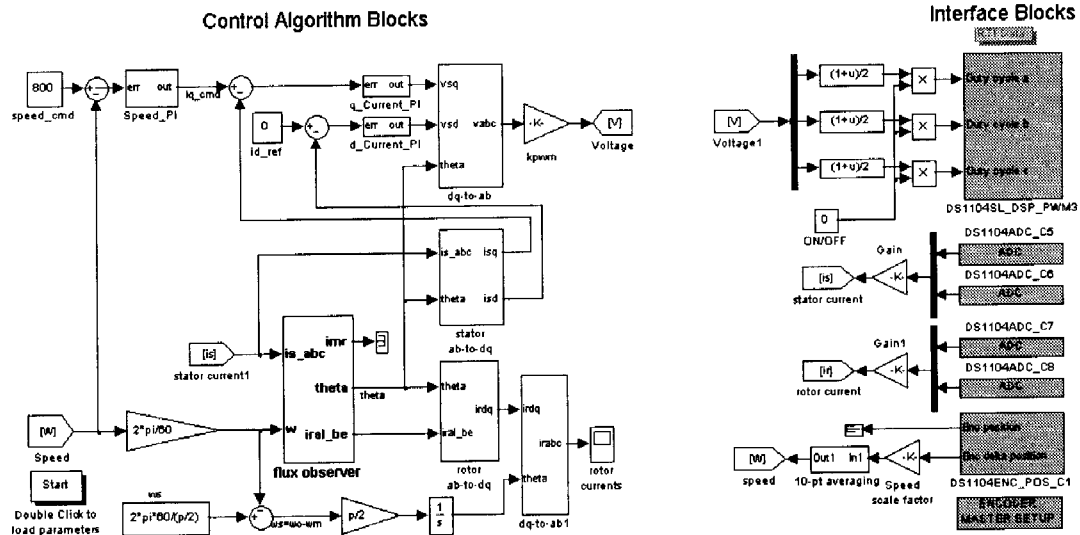

Fig. 7 Implementation on dSPACE

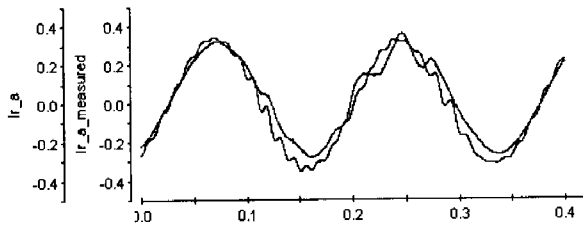

Fig. 8 Measured rotor currents with comparison to the estimated rotor currents

6. CONCLUSION

This paper has demonstrated a field oriented control of an induction machine with direct estimation of rotor current. The experiment on a wound rotor induction motor confirmed the proposed method. The proposed method is directly applicable to electric or hybrid electric vehicle drivetrain and other applications.

Acknowledgment

The authors would like to thank the funding support from the Center for Engineering Education and Practice (CEEP) at the University of Michigan-Dearborn.

References

Belmans, R., F. Busschots, R. Timmer, Practical design considerations for braking problems in overhead crane drives, *Conference Record of the 1993 IEEE Industry Applications Society Annual Meeting*, 473-479, 1993.

Casadei, D., G. Serra, A. Tani, Direct flux and torque control of induction machine for electric vehicle applications, *Seventh International Conference on Electrical Machines and Drives*, 349-353, 1995.

Chan, C. C., The state of the art of electric and hybrid

vehicles, *Proceedings of the IEEE*, Vol. 90, No. 2, 247-275, 2002.

Jezernik, K., Robust direct torque and flux vector control of induction motor, *Proceedings of the 24th Annual Conference of the IEEE Industrial Electronics Society, IECON '98.*, Vol. 2, 667-672, 1998.

Krause, P. C., *Analysis of Electrical Machinery*, McGraw-hill Book Company, 1987.

Mi, C., J. Shen., and N. Natarajar, Field-Oriented Control of Induction Machines using Motorola MC68332 Microcontroller, *IEEE Workshop on Power Electronics in Transportation, WPET'2002*, 69-73, 2002.

Pagano, E., O. Veneri, Regenerative and plug braking operations of asynchronous drives for electric road vehicles, *International Conference on Electric Machines and Drives, IEMD'99*, 443-445, 1999.

Park, R. H., Two-Reaction Theory of Synchronous Machines-II, *Trans. AIEE*, Vol. 51, 352-355, 1932.

Rahman, M. F., L. Zhong, A single/two-phase, regenerative, variable speed, induction motor drive with sinusoidal input current, *Conference Record of the 1995 IEEE Industry Applications Society Thirtieth Annual Meeting*, Vol. 1, 584-590, 1995.

(Received July 2, 2007; accepted August 30, 2007)