

Design and Control of an Isolated Bidirectional DC-DC Converter for Hybrid Electric Vehicle Applications

Sonya Gargies¹, Hongjie Wu², and Chris Mi³

¹ US Army TARDEC, sonya.gargies@us.army.mil

² Department of Electrical and Computer Engineering, University of Michigan, wuhj@umd.umich.edu

³ Department of Electrical and Computer Engineering, University of Michigan, chrismi@umich.edu

Abstract

Hybrid electric vehicles (HEVs) offer many advantages, such as high fuel economy, low emissions, and silent operation. In HEVs, there are two or more different voltage buses for different purposes of the vehicle operation. There are needs of galvanically isolated bidirectional DC-DC converter to link different DC voltage bus and transfer energy back and forth. For example, one of the DC-DC converters convert the high voltage (200-300V) in the main battery to low voltage (-12V) for use in electrical equipment, while the other converts 300V battery voltage and supply the drive motor with 500V. High efficiency, compact size, lightweight, and reliability are all essential requirements for DC-DC converters for electric and hybrid vehicles. This paper introduces a bidirectional, isolated DC-DC converter for medium power applications. A dual full-bridge topology is developed to achieve the power rating. A 1kW prototype of the converter has been built and tested. The experimental results of the converter's steady state operation confirm the simulation analysis. This converter is a first step to understanding the design and build of a medium power DC-DC converter.

Keywords

power converter, DC-DC, hybrid electric vehicle, battery, galvanically isolation

1. INTRODUCTION

Hybrid electric vehicles (HEVs) combine the internal combustion engine of a conventional vehicle with the battery and electric motor of an electric vehicle. The combination offers low emissions while provides comparable driving range and convenient fueling of conventional (gasoline and diesel) vehicles without the need to be plugged in. The inherent flexibility of HEVs makes them suited for personal transportation and military applications. HEVs are powered by an on-board energy source (gasoline or diesel engine), an energy conversion unit (such as a combustion engine or fuel cell) and an energy storage device (such as batteries or ultracapacitors). The energy conversion unit may be powered by gasoline, methanol, compressed natural gas, hydrogen, or other alternative fuels. Hybrid electric vehicles have the potential to be two to three times more fuel-efficient than conventional vehicles. An HEV is an optimized mix of various components. The integration of these power-producing components with the electrical energy storage components allows for many different types of HEV designs. A power control strategy is needed to control the flow of power and to maintain adequate reserves of energy in the storage devices. Al-

though this is an added complexity that is not found in conventional vehicles, it allows the components to work together in an optimal manner to achieve multiple design objectives, such as high fuel economy and low emissions while maintaining or improving performance such as acceleration, range, noise, silent operation, etc. The control strategy brings the components together as a system and provides the intelligence that makes the components work together through mechanical and electrical control. Mechanical control includes clutch control, throttle control, and other controls activated mechanically by the driver from the car's interior. Electrical control will most likely be the dominant means of implementing control strategies. This will be done through software programs running on microchips that then activate relays and other electromechanical systems to perform the desired functions. These computing systems will have multiple data inputs measured on the current state of the vehicle (such as component temperatures, battery voltage, current, and state of charge) as well as the standard desired response requested by the driver (such as braking and acceleration). This is all due to the increased use of on-board computers in current and future vehicles. One main component for the control of power is a DC-DC converter. In hybrid vehicles, the DC-DC converter converts the high voltage (200-300V) in the main battery to low voltage (14-42 V) or higher voltage (400-600V) for use in electrical

equipment, thereby serving as an electrical unit that is indispensable for use in the next generation of clean energy vehicles. High efficiency, compact size, lightweight, and reliability are all essential requirements for DC-DC converters for electric and hybrid vehicles, but an important concern is how to increase efficiency [Doncker *et al.*, 2003; Li *et al.*, 2003; Peng *et al.*, 2003; Fan *et al.*, 2004; Xu *et al.*, 2004; Chen *et al.*, 2001; Brown, 2001].

DC-DC converters are switching regulators that offer higher efficiency than linear regulators. They can step-up, step-down, and invert the input voltage. Switching regulators use an inductor, transformer, or a capacitor as an energy storage element to transfer energy from input to output. Feedback circuitry regulates the energy transfer to maintain a constant voltage or constant current within the load limits of the circuit [Mohan, 1989]. Army HEVs are designed to use a high-voltage DC bus to supply high power electrical subsystems that may benefit from a variable-voltage bi-directional DC-DC converter to interface between the main storage battery pack and the high-voltage bus. The use of such a DC-DC converter has the potential to improve overall efficiency, fuel economy, reliability, and safety, with the proper controls and feedback circuitry. It would allow a battery pack operating at a low voltage to supply higher voltage to the vehicle. To provide these advantages (efficiency, fuel economy, reliability, and safety) and to meet Army goals for enhanced sustainability, transportability and maintainability, it is desirable that the converter be compact, lightweight, and efficient. Technologies used in the DC-DC converter must be suitable for use in a combat vehicle. The converter designed and built for this project must be able to provide a voltage dc bus of 200V, from a lower voltage (36-44V) battery pack or a dc supply input. The converter must be capable of isolating the main input voltage from the high-voltage output.

This paper introduces a bidirectional, isolated DC-DC converter for medium power applications. A dual full-bridge topology is developed to achieve the requirements. A 1kW prototype converter has been built and tested. The experimental results of the converter's steady state operation confirm the simulation analysis. This converter is a first step to understanding the design and build of a medium power DC-DC converter.

Since a high voltage is produced in the majority power systems on hybrid vehicles, it becomes imperative to have a DC-DC converter to supply all the auxiliary loads on a vehicle. Although the technology is well developed for low power converters (a few watts), further work needs to be done for high-power applications. It is a big challenge to meet all the vehicle standards for EMI, efficiency, and packaging. Since the ratio of volt-

age conversion is going to be high (e.g. 40V to 200V or 320V to 12V), it is necessary to have isolation or a transformer interface and use a combination of devices. Several topologies are possible, and evaluation and development of the optimized converter are still a challenge. In addition, an IGBT device maybe used for the front end of the converter and a MOSFET for the output switching devices. Every part of the design becomes crucial, the topology selected, the power rating, choice of switching frequency, soft/hard switching, choice of switches, packaging, thermal considerations, etc. A high priority should also be given to increasing the power density by increasing the switching frequency and level of component integration; however this paper is focused on understanding how the DC-DC converter works and what are the critical issues involved in the design and construction.

2. THE PROPOSED DC-DC CONVERTER

There are many different types of DC-DC converters available, each of which is more suitable for some type of application. Some converters are only suitable for stepping down the voltage, while others for stepping up the voltage, and a third group can be for either. An important distinction is full isolation between their input and output circuits. Non-isolated converters are generally used where the voltage needs to be stepped up or down. The main types of converter in non-isolating group are buck, buck-boost, cuk, and charge-pump converters, which are used for either step up or voltage inversion in relatively low power applications. For applications where the output needs to be completely isolated from the input, isolating converters are implemented. The two main isolating converters are the flyback and fly forward converters that both depend on energy stored in the magnetic field of an inductor or a transformer. These topologies are used for low power applications. For higher power applications, the half-bridge or the full bridge topology is used. The input to output isolation of a converter can be used to generate different voltage rails and/or dual-polarity. The primary need for isolation is to satisfy safety requirements when going to higher power levels. Typically, isolated converters are both larger and more expensive than non-isolated solutions. For this project, isolation is part of the requirement due to the high power requirement, bidirectionality, and safety. An isolated full-bridge DC-DC converter is designed and implemented.

There are three distinct applications of the full-bridge switch-mode converters: dc-motor drives, DC-AC conversion in single-phase uninterruptible AC power supplies, AC-DC conversion in switch-mode transformer isolated DC power supplies. Even though the full-bridge topology as shown in Figure 1 remains the same in each

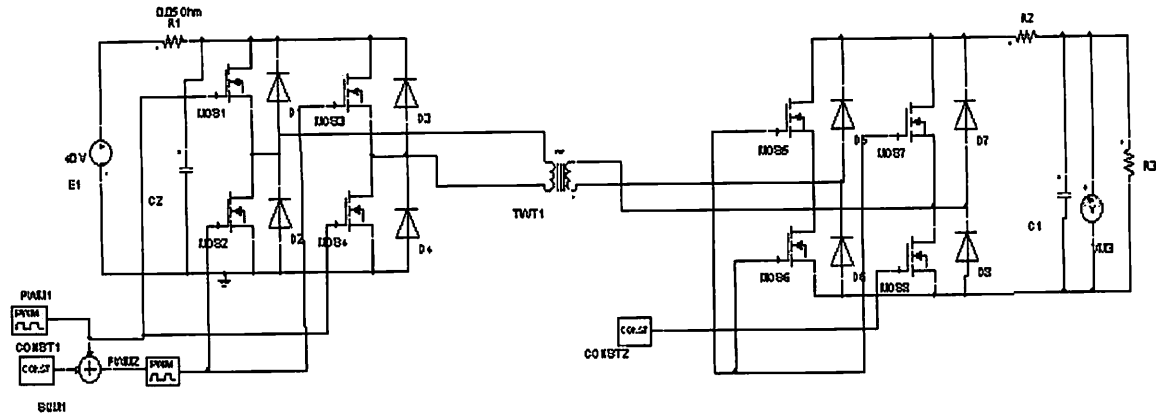

Fig. 1 The topology and modeling of the proposed DC-DC converter

of these three applications, the type of control depends on the application.

In the full-bridge converter, the input is a DC voltage input. The output of the converter is a DC voltage output which can be controlled in magnitude as well as polarity. In a converter topology such as that of a full-bridge converter where diodes are connected in anti-parallel with the switches, a distinction must be made between the on-state versus the conducting stage of a switch. Because of the diodes in anti-parallel with the switches, when a switch is turned ON, it may or may not conduct a current, depending on the direction of the output current. If the switch conducts a current, then it is in a conducting state. No such distinction is required when the switch is turned off. The full-bridge converter consists of two legs and each leg consists of two switches and their anti-parallel diodes. The two switches in each leg are switched in such a way that when one of them is in its OFF state, the other switch is ON. They are both off for a short time interval, to avoid short-circuiting of the DC input. If the converter switches in a leg are not off simultaneously, then the output current will flow continuously. The output voltage is dictated by the status of the switches. It is possible to control the output voltage of a converter leg by turning both switches off simultaneously for some time interval.

Most DC-DC converter designs evolve around the full-bridge, forward, and half bridge converters. Among the possibilities for the power level around 1kW, the half-

bridge and full-bridge converter provide the best combination of simple structure. Figure 1 shows the proposed structure of the bidirectional DC-DC converter that also offers the capability for isolation. Figure 2 shows the simulated output of the isolated converter with 50% duty ratio on both sides of the converter. The power transfer is bidirectional. Output voltage can be controlled by employing a feedback and controlling the phase shift of the output bridge.

3. CIRCUIT DESIGN

The Full-Bridge DC-DC converter will have to maintain a constant 200V DC output with a varying 36-44V DC input (40V nominal). This is accomplished by the Pulse Width Modulation (PWM) controller. Full bridge topologies have been used for DC-DC converters using a PWM. A full-bridge converter can generate the highest output power among most converter topologies. The full-bridge converter requires a total of four switching transistors to perform DC-DC conversion. An important feature of the full-bridge design is the isolation provided by the switching transformer.

Designing the control circuit is another part of the DC-DC converter requirements. The control circuit is designed based on the desired switching frequency of the MOSFETS and the duty cycle [Blake et al.; Penton Media, 1999; Travis, 1999]. Using the Texas Instrument (TI) UC3846 Current Mode PWM Controller specification sheet, the resistor R_T and the capacitor C_T values can be calculated using the formula provided. Oscillator frequency is approximated by (1).

$$f_T (kHz) = \frac{2.2}{R_T (k\Omega) * C_T (\mu F)} \quad (1)$$

From the application notes, it is recommended by TI to use R_T values between 1k Ω to 100k Ω . The switching

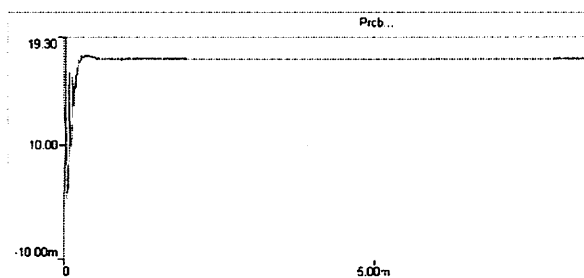

Fig. 2 Simulated output of the converter

frequency chosen for this project is 50kHz and the duty cycle is 50% or 0.5. RT was chosen to be 5.5kΩ and the CT values were calculated to be 0.1μF. The UC3846 Current Mode PWM controller adjusts the duty cycle of the high and low side outputs to the IR2110 gate drives to achieve the 200VDC output. A current mode controller was chosen instead of a voltage mode control. Current mode is used for the following conditions: if the power supply output is to be a current source or very high output voltage. The application is for a DC-DC converter where the input voltage variation is relatively constrained, modular applications where parallelability with load sharing is required, in push-pull circuits where transformer flux balancing is important, and in low cost applications requiring the absolute fewest components. Considerations of voltage mode should be taken if there are wide input line and/or output load variations possible, particularly with low line - light load conditions where the current ramp slope is too shallow for stable PWM operation, high power and/or noisy applications where noise on the current waveform would be difficult to control, multiple output voltages are needed with relatively good cross-regulation, saturable reactor controllers are to be used as auxiliary secondary side regulators, and applications where the complexities of dual feedback loops and/or slope compensation is to be avoided. After considerations of the requirements for

this project, the conclusion is that the current mode control will ease many limitations of voltage mode; however, it may contribute extra challenges to the design. A significant reason to go with current control rather than voltage mode control for this circuit is load sharing [Texas Instruments, 1999]. Gate driver circuit, bootstrap capacitor and other circuit components are then designed [Burt *et al.*, 1991; Merello *et al.*, 2004; Adams, 2001].

The gate driver circuit is shown in Figure 3. The model of the main switching circuit is shown in Figure 4 and the simulated voltage response of the bidirectional converter is shown in Figure 5. The actual hardware of the prototype is shown in Figure 6.

4. EXPERIMENTAL

The design was built and tested. In Figure 7, the converter was tested to show the output waveform at maximum power supply potential that was provided in the Power Electronics laboratory. Figure 7 (a) displays the upper gate drive waveform shown in blue and the output waveform shown in pink at 5V input and a measured 28.8V output. Figure 7 (b) displays the stable upper gate drive signal and the output waveform in pink at an input voltage of 8.78V and a measured output of 50V. The output waveform has a small ripple; however, the results demonstrate the converter is operating as ex-

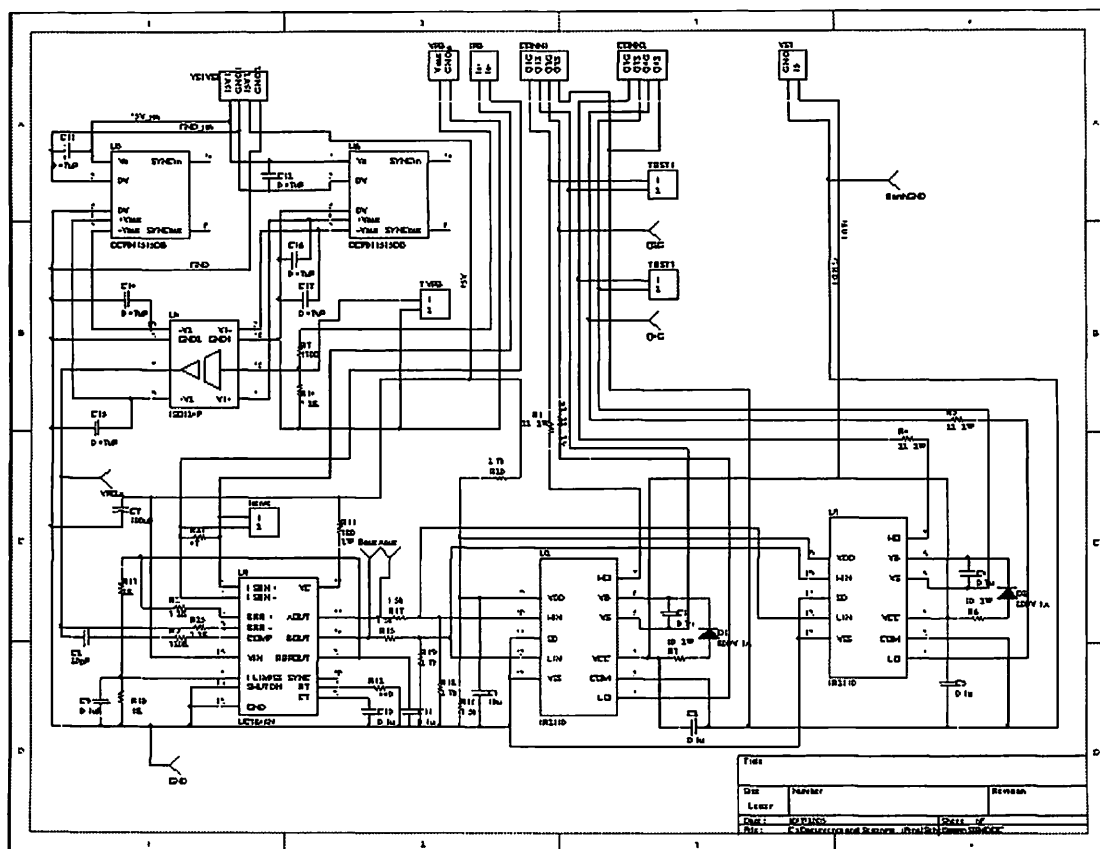

Fig. 3 The gate driver circuit design

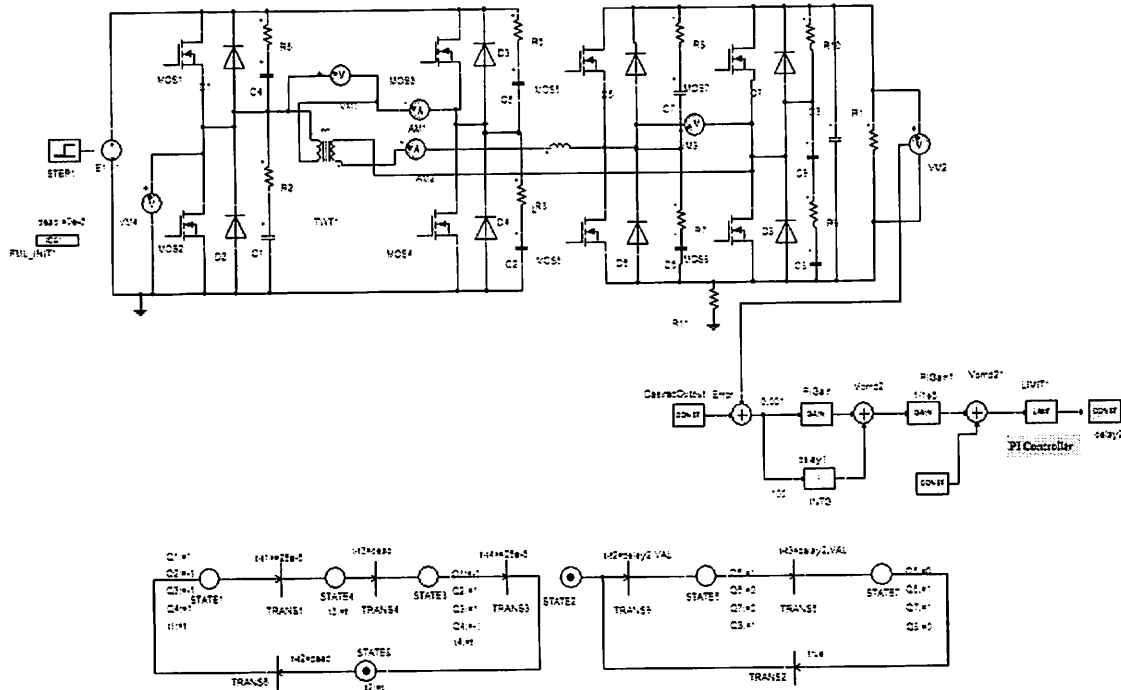

Fig. 4 Modeling of the bidirectional converter: voltage and current control of the secondary

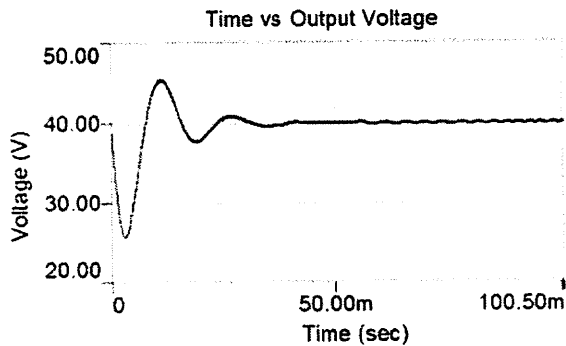

Fig. 5 Simulated output of the bidirectional converter with PID control

pected. In order to reduce the ripple, a filter capacitor can be added to the input and a larger capacitor can be added to the output.

5. CONCLUSION

The paper presents detailed modeling, design, and experimentation of the 1kW bidirectional isolated DC-DC converter. The design is based on a mix of theoretical analysis, simulations, and hardware implementations. The detailed design and experiment confirmed the requirement specifications. Experiments validated the characteristics and performance shown in the simulations and in the theoretical analysis. A controller has been designed and the simulation results show that the converter system has a satisfactory transient response

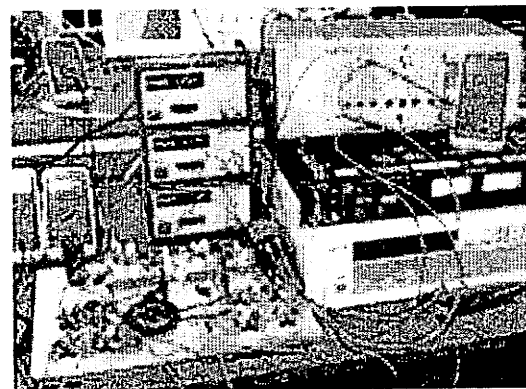

Fig. 6 Experimental setup of the prototype

against load variation and distributed voltage. The simulations and calculations illustrate that the full-bridge topology is a suitable choice for this power range. Since this is a preliminary prototype, it is recommended that the next phase is to scale the converter to 10kW

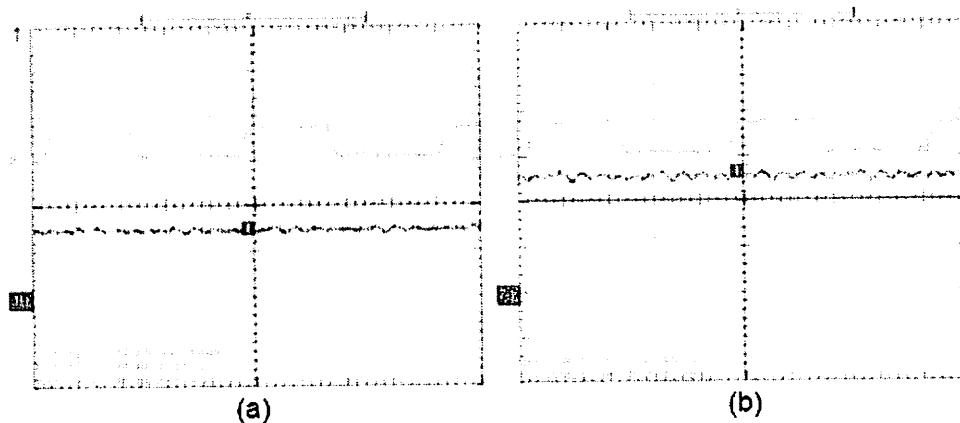

Fig. 7 (a) the blue curve displays the upper gate drive signal and the pink waveform displays the output at an input of 5V. The measured output is 28.8V; and (b) the blue curve displays the upper gate drive signal and pink waveform is the output voltage at 50V with an input of 8.78V

with a focus on optimum power density and the use of new power devices such as silicon carbide switches and/or diodes.

References

- Adams, J., Bootstrap Component Selection for Control IC's, *International Rectifier Design Tip*, DT-98-2a, 2001.
- A New Integrated Circuit For Current Mode Control. *Texas Instruments Unitrode Application Note*, U-93, 1999. <http://focus.ti.com/lit/an/slua075/slua075.pdf>
- Blake, C., and C. Bull, IGBT or MOSFET: Choose Wisely, *International Rectifier*.
- Brown, M., *Power Supply Cookbook Second Edition*, Newnes Butterworth-Heinemann, 2001.
- Burt, R., and R. M. Stitt, Single-Supply Operation of Isolation Amplifiers, *Burr-Brown Application Bulletin*, AB-009a, 1991.
- Chen, G., D. Xu, and Y. Wang, A New Family of Soft-Switching Phase-Shift Bidirectional DC-DC Converters, *IEEE*, 2001.
- Fan, H., and D. Xu, A Family of PWM plus Phase-Shift Bidirectional DC-DC Converters, *35th Annual IEEE Power Electronics Specialists Conference*, 2004.
- Li, H., F. Z. Peng, and J. S. Lawler, A Natural ZVS Medium-Power Bidirectional DC-DC converter with Minimum Number of Devices, *IEEE Transactions on Industry Applications*, Vol. 39, No. 2, 2003.
- Merello, A., A. Rugginenti, and M. Grasso, Using Monolithic high voltage gate drivers, *International Rectifier Design Tips*, DT 04-4, 2004.
- Mohan, U., and Robbins, *Power Electronics: Converters, Applications and Design*, Wiley, 1989.
- Peng, F. Z., F. Zhang, and Z. Qian, A Novel DC-DC Converter for 42V Systems, *IEEE Transactions*, Vol. 0-7803-7754-0/03, 2003.
- Penton Media, Inc., IGBTs or MOSFETs: Which is Better For Your Design, ED Online ID #7501, 1999, www.elecdesign.com/Articles/Print.cfm?ArticleID=7501.
- Rik, W., D. Doncker, and J. Walter, High-Power Galvanically Isolated DC/DC Converter topology for Future Automobiles, *IEEE Transactions*, 2003.
- Travis, B., IGBTs and MOSFETs vie for application, *EDN Magazine*, 1999.
- Xu, D., C. Zhao, and H. Fan, A PWM Plus Phase-Shift Control Bidirectional DC-DC Converter, *IEEE Transactions on Power Electronics*, Vol. 19, No. 3, 2004.